

Power-Bolt® Heavy-Duty Sleeve Anchor

PRODUCT DESCRIPTION

The Power-Bolt anchor, formerly known as the *Rawl-Bolt*, is a heavy duty sleeve style, self-locking anchor which is vibration resistant and removable. It is available with a finished hex head or flat head with a hex key insert and can be used in concrete, block, brick, or stone.

Expansion occurs at two locations within the drilled hole. First, the cone is pulled into the large triple-tined expansion sleeve, developing a mid-level, compression force. Further turning causes the threaded bolt to advance into the threads of the expander cone, forcing its four sections outward. This action undercuts the base material deep in the anchor hole, greatly increasing the holding power of the Power-Bolt. The bolt and cone remain locked together which prevents loosening under even the most severe vibratory conditions.

The Power-Bolt is also designed to draw the fixture into full bearing against the base material through the action of its flexible compression ring. As the anchor is being tightened, the compression ring will crush if necessary to tightly secure the fixture against the face of the base material.

The internal bolt of the Power-Bolt is removable and reusable in the same anchor hole making it ideal for applications such as mounting machinery which may need to be removed for service and for temporary applications such as heavy duty form work.

GENERAL APPLICATIONS AND USES

- Seismic Bracing and Vibratory Applications
- Column Base Plates and Mechanical Equipment
- Dock Bumpers and Support Ledgers
- Racking and Railing Attachments
- Overhead and Critical Anchoring

FEATURES AND BENEFITS

- High load capacity
- Tested in accordance with ASTM E488 and AC01 criteria
- Qualified for seismic and wind load applications
- Two-level expansion mechanism
- Suitable for vibratory, fatigue and shock loading
- Internal high strength bolt is removable and reusable
- Compression zone clamps fixture to the base material
- Low profile finished head design
- Fire tested per Ref. WFRA No. F91763

APPROVALS AND LISTINGS

International Code Council, Evaluation Service (ICC-ES) ESR-1532
(formerly listed in ICBO ES ER-5225)
Southern Building Code Conference International (SBCCI) #9943A
City of Los Angeles (COLA) Research Report LARR – 24960
Florida Building Code Approval – FL2209.4
Miami-Dade County Notice of Acceptance (NOA) 03-0303.14
Factory Mutual Research Corporation (FM Approvals) – File No. J.I. 1K8A3.AH
Underwriters Laboratory (UL Listed) – File No. EX1289
Federal GSA Specification – Meets the proof load requirements of FF-S-325C, Group II,
Type 3, Class 3 (superseded)
Various North American Departments of Transportation (DOT) – See www.powers.com

GUIDE SPECIFICATIONS

CSI Divisions: 03151-Concrete Anchoring, 04081-Masonry Anchorage and 05090-Metal Fastenings. Expansion Anchors shall be Power-Bolt anchors as supplied by Powers Fasteners, Inc., Brewster, NY.

SECTION CONTENTS Page No.

General Information.....	28
Installation Specifications	29
Material Specifications	30
Performance Data	31
Design Criteria	36
Ordering Information	39



Hex Head Power-Bolt

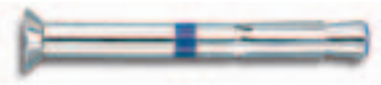

Flat Head Power-Bolt

HEAD STYLES

Finished Hex Head
Flat Head

ANCHOR MATERIALS

Zinc Plated Carbon Steel
Type 304 Stainless Steel

ANCHOR SIZE RANGE (TYP.)

1/4" diameter x 1" length to
3/4" diameter x 8-1/4" length

SUITABLE BASE MATERIALS

Normal-Weight Concrete
Structural Lightweight Concrete
Grouted Concrete Masonry
Hollow CMU
Brick Masonry
Stone

INSTALLATION SPECIFICATIONS

Carbon Steel Hex Head Power-Bolt

Dimension	Anchor Diameter, <i>d</i>					
	1/4"	5/16"	3/8"	1/2"	5/8"	3/4"
ANSI Drill Bit Size, <i>d_{bit}</i> (in.)	1/4	5/16	3/8	1/2	5/8	3/4
Fixture Clearance Hole, <i>d_h</i> (in.)	5/16	3/8	7/16	9/16	11/16	13/16
Internal Bolt Size (UNC)	10-24	1/4-20	5/16-18	3/8-16	1/2-13	5/8-11
Head Height (in.)	7/64	11/64	13/64	15/64	5/16	25/64
Washer O.D., <i>d_w</i> (in.)	1/2	5/8	13/16	1	1-1/4	1-1/2
Wrench Size (in.)	5/16	7/16	1/2	9/16	3/4	15/16
Max. Tightening Torque, <i>T_{max}</i> (ft-lbs)	3-4	10-12	20-25	35-45	80-100	95-120
Bearing Area (in ²)	0.070	0.105	0.145	0.246	0.370	0.515

Carbon Steel Flat Head Power-Bolt (80°–82° head)

Dimension	Anchor Diameter, <i>d</i>		
	3/8"	1/2"	5/8"
ANSI Drill Bit Size, <i>d_{bit}</i> (in.)	3/8	1/2	5/8
Fixture Clearance Hole, <i>d_h</i> (in.)	7/16	9/16	11/16
Internal Bolt Size (UNC)	5/16-18	3/8-16	1/2-13
Head Height (in.)	15/64	1/4	21/64
Head Diameter, <i>d_{hd}</i> (in.)	3/4	7/8	1-1/8
Allen Wrench Size (in.)	7/32	5/16	3/8
Max. Tightening Torque, <i>T_{max}</i> (ft-lbs)	20-25	35-45	80-100
Bearing Area (in ²)	0.145	0.246	0.370

Stainless Steel Hex Head Power-Bolt

Dimension	Anchor Diameter, <i>d</i>				
	1/4"	3/8"	1/2"	5/8"	3/4"
ANSI Drill Bit Size, <i>d_{bit}</i> (in.)	1/4	3/8	1/2	5/8	3/4
Fixture Clearance Hole, <i>d_h</i> (in.)	5/16	7/16	9/16	11/16	13/16
Internal Bolt Size (UNC)	10-24	5/16-18	3/8-16	1/2-13	5/8-11
Head Height (in.)	7/64	13/64	15/64	5/16	25/64
Washer O.D., <i>d_w</i> (in.)	1/2	13/16	1	1-1/4	1-1/2
Wrench Size (in.)	5/16	1/2	9/16	3/4	15/16
Max. Tightening Torque, <i>T_{max}</i> (ft-lbs)	2-3	10-12	20-25	45-60	70-90
Bearing Area (in ²)	0.070	0.145	0.246	0.370	0.515

Installation Procedure

Using the proper diameter bit, drill a hole into the base material to a depth of at least 1/2" or one anchor diameter deeper than the embedment required. The tolerances of the drill bit used should meet the requirements of ANSI Standard B212.15.



Blow the hole clean of dust and other material. Do not expand the anchor or advance the bolt in the anchor assembly prior to installation.



Drive the anchor through the fixture into the anchor hole until the bolt head is firmly seated against the fixture. Be sure the anchor is driven to the required embedment depth.



Tighten the anchor by turning the head 3 to 5 turns past finger tight or by applying the guide installation torque from the finger tight position.

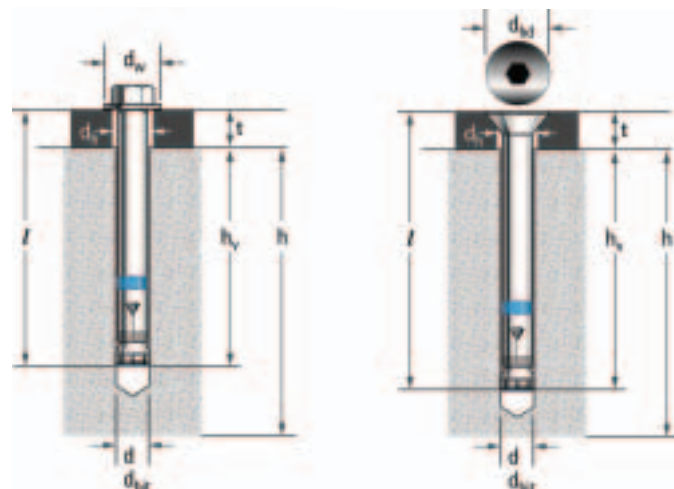

Nomenclature

- d* = Diameter of anchor
- d_{bit}* = Diameter of drill bit
- d_h* = Diameter of fixture clearance hole
- d_{hd}* = Flat head diameter
- d_w* = Diameter of washer
- h* = Base material thickness.
The minimum value of *h* should be 1.5*h_v*.
- h_v* = Minimum embedment depth
- l* = Overall length of anchor
- t* = Fixture thickness
- T_{max}* = Maximum tightening torque

MATERIAL SPECIFICATIONS

Anchor Component	Carbon Steel Hex Head	Carbon Steel Flat Head	Stainless Steel Hex Head
Internal Bolt	*SAE Grade 5	SAE Grade 5	**Type 304 SS
Washer	AISI 1040	N/A	Type 18-8 SS
Expander Sleeve	AISI 1010	AISI 1010	Type 304 SS
Extension Sleeve	AISI 1010	AISI 1010	Type 304 SS
Expander Cone	AISI 12L14	AISI 12L14	Type 303 SS
Compression Ring	Nylon	Nylon	Nylon
Dust Cap	Nylon	Nylon	Nylon
Plating	ASTM B 633, SC1, Type III (Fe/Zn 5) – Zinc		N/A

* 1/4" and 5/16" Power-Bolts are manufactured with SAE Grade 8 internal bolts.
 ** Manufactured with a minimum yield strength of 65,000 psi.
 Stainless steel anchor components are passivated.

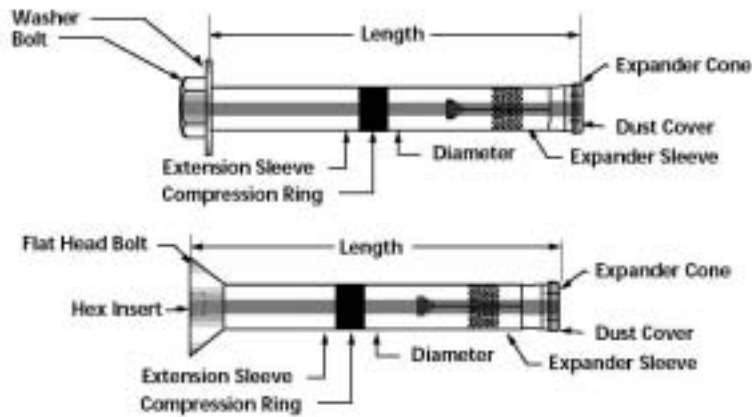

Length Identification

Mark	◆	■	A	B	C	D	E	F	G	H	I	J	K	L	M	N	O	P
From	1/2"	1"	1-1/2"	2"	2-1/2"	3"	3-1/2"	4"	4-1/2"	5"	5-1/2"	6"	6-1/2"	7"	7-1/2"	8"	8-1/2"	9"
Up to but not including	1"	1-1/2"	2"	2-1/2"	3"	3-1/2"	4"	4-1/2"	5"	5-1/2"	6"	6-1/2"	7"	7-1/2"	8"	8-1/2"	9"	9-1/2"

PERFORMANCE DATA

Ultimate Load Capacities for Carbon and Stainless Steel Power-Bolt in Normal-Weight Concrete^{1,2}

Anchor Diameter <i>d</i> in. (mm)	Minimum Embedment Depth <i>h_v</i> in. (mm)	Minimum Concrete Compressive Strength (<i>f'_c</i>)							
		2,000 psi (13.8 MPa)		3,000 psi (20.7 MPa)		4,000 psi (27.6 MPa)		6,000 psi (41.4 MPa)	
		Tension lbs. (kN)	Shear lbs. (kN)	Tension lbs. (kN)	Shear lbs. (kN)	Tension lbs. (kN)	Shear lbs. (kN)	Tension lbs. (kN)	Shear lbs. (kN)
1/4 (6.4)	1 1/4 (31.8)	1,180 (5.3)	2,070 (9.3)	1,380 (6.2)	2,100 (9.5)	1,580 (7.1)	2,130 (9.6)	1,660 (7.5)	2,130 (9.6)
	1 3/4 (44.5)	1,400 (6.3)	2,070 (9.3)	1,550 (7.0)	2,305 (10.4)	1,700 (7.7)	2,540 (11.4)	1,860 (8.4)	2,540 (11.4)
	2 1/2 (63.5)	1,880 (8.5)	2,070 (9.3)	1,940 (8.7)	2,730 (12.3)	2,000 (9.0)	3,385 (15.2)	2,100 (9.5)	3,385 (15.2)
5/16 (7.9)	1 1/2 (38.1)	2,320 (10.4)	2,800 (12.6)	2,430 (10.9)	3,000 (13.5)	2,540 (11.4)	3,200 (14.4)	2,620 (11.8)	3,200 (14.4)
	2 (50.8)	2,640 (11.9)	3,280 (14.8)	2,880 (13.0)	3,755 (16.9)	3,120 (14.0)	4,230 (19.0)	3,270 (14.7)	4,230 (19.0)
	3 (76.2)	2,880 (13.0)	3,440 (15.5)	3,330 (15.0)	4,410 (19.8)	3,780 (17.0)	5,380 (24.2)	4,260 (19.2)	5,380 (24.2)
3/8 (9.5)	2 (50.8)	3,500 (15.8)	3,985 (17.9)	4,045 (18.2)	5,205 (23.4)	4,585 (20.6)	6,425 (28.9)	5,915 (26.6)	7,440 (33.5)
	2 1/2 (63.5)	3,800 (17.1)	4,380 (19.7)	4,330 (19.5)	5,770 (26.0)	4,855 (21.8)	7,160 (32.2)	6,665 (30.0)	7,960 (35.8)
	3 1/2 (88.9)	4,395 (19.8)	4,980 (22.4)	5,195 (23.4)	6,815 (30.7)	5,995 (27.0)	8,650 (38.9)	7,150 (32.2)	8,650 (38.9)
1/2 (12.7)	2 1/2 (63.5)	4,900 (22.1)	6,840 (30.8)	5,710 (25.7)	7,535 (33.9)	6,520 (29.3)	8,225 (37.0)	7,320 (32.9)	8,225 (37.0)
	3 1/2 (88.9)	6,140 (27.6)	8,540 (38.4)	7,590 (34.2)	9,200 (41.4)	9,040 (40.7)	9,860 (44.4)	9,890 (44.5)	10,780 (48.5)
	5 (127.0)	7,260 (32.7)	10,140 (45.6)	8,480 (38.2)	11,230 (50.5)	9,700 (43.7)	12,320 (55.4)	10,935 (49.2)	12,315 (55.4)
5/8 (15.9)	2 3/4 (69.9)	5,360 (24.1)	7,970 (35.9)	6,535 (29.4)	9,970 (44.9)	7,705 (34.7)	11,970 (53.9)	8,490 (38.2)	11,970 (53.9)
	4 (101.6)	6,460 (29.1)	10,860 (48.9)	8,210 (36.9)	12,710 (57.2)	9,960 (44.8)	14,560 (65.5)	13,110 (59.0)	15,900 (71.6)
	6 (152.4)	9,400 (42.3)	13,780 (62.0)	10,570 (47.6)	16,230 (73.0)	11,740 (52.8)	18,680 (84.1)	15,580 (70.1)	18,670 (84.0)
3/4 (19.1)	3 (76.2)	7,660 (34.5)	12,375 (55.7)	8,580 (38.6)	14,245 (64.1)	9,500 (42.8)	16,110 (72.5)	10,780 (48.5)	16,110 (72.5)
	4 1/2 (114.3)	10,060 (45.3)	16,900 (76.1)	11,200 (50.4)	20,250 (91.1)	12,340 (55.5)	23,600 (106.2)	16,240 (73.1)	23,600 (106.2)
	7 (177.8)	11,780 (53.0)	22,640 (101.9)	13,440 (60.5)	25,880 (116.5)	15,100 (68.0)	29,120 (131.0)	21,980 (98.9)	29,120 (131.0)

1. The values listed above are ultimate load capacities which should be reduced by a minimum safety factor of 4.0 or greater to determine the allowable working load.
2. Linear interpolation may be used to determine ultimate loads for intermediate embedments and compressive strengths.

MECHANICAL ANCHORS

PERFORMANCE DATA

Allowable Load Capacities for Carbon and Stainless Steel Power-Bolt in Normal-Weight Concrete^{1,2,3}

Anchor Diameter <i>d</i> in. (mm)	Minimum Embedment Depth <i>h_v</i> in. (mm)	Minimum Concrete Compressive Strength (<i>f_c</i>)							
		2,000 psi (13.8 MPa)		3,000 psi (20.7 MPa)		4,000 psi (27.6 MPa)		6,000 psi (41.4 MPa)	
		Tension lbs. (kN)	Shear lbs. (kN)	Tension lbs. (kN)	Shear lbs. (kN)	Tension lbs. (kN)	Shear lbs. (kN)	Tension lbs. (kN)	Shear lbs. (kN)
1/4 (6.4)	1 1/4 (31.8)	295 (1.3)	515 (2.3)	345 (1.6)	525 (2.4)	395 (1.8)	535 (2.4)	415 (1.9)	530 (2.4)
	1 3/4 (44.5)	350 (1.6)	515 (2.3)	390 (1.8)	575 (2.6)	425 (1.9)	635 (2.9)	465 (2.1)	635 (2.9)
	2 1/2 (63.5)	470 (2.1)	515 (2.3)	485 (2.2)	680 (3.1)	500 (2.3)	845 (3.8)	525 (2.4)	845 (3.8)
5/16 (7.9)	1 1/2 (38.1)	580 (2.6)	700 (3.2)	610 (2.7)	750 (3.4)	635 (2.9)	800 (3.6)	655 (2.9)	800 (3.6)
	2 (50.8)	660 (3.0)	820 (3.7)	720 (3.2)	940 (4.2)	780 (3.5)	1,060 (4.8)	820 (3.7)	1,060 (4.8)
	3 (76.2)	720 (3.2)	860 (3.9)	835 (3.8)	1,105 (5.0)	945 (4.3)	1,345 (6.1)	1,065 (4.8)	1,345 (6.1)
3/8 (9.5)	2 (50.8)	875 (3.9)	995 (4.5)	1,010 (4.5)	1,300 (5.9)	1,145 (5.2)	1,605 (7.2)	1,480 (6.7)	1,860 (8.4)
	2 1/2 (63.5)	950 (4.3)	1,095 (4.9)	1,080 (4.9)	1,445 (6.5)	1,215 (5.5)	1,790 (8.1)	1,665 (7.5)	1,990 (9.0)
	3 1/2 (88.9)	1,100 (5.0)	1,245 (5.6)	1,300 (5.9)	1,705 (7.7)	1,500 (6.8)	2,165 (9.7)	1,790 (8.1)	2,165 (9.7)
1/2 (12.7)	2 1/2 (63.5)	1,225 (5.5)	1,710 (7.7)	1,430 (6.4)	1,885 (8.5)	1,630 (7.3)	2,055 (9.2)	1,830 (8.2)	2,055 (9.2)
	3 1/2 (88.9)	1,535 (6.9)	2,135 (9.6)	1,900 (8.6)	2,300 (10.4)	2,260 (10.2)	2,465 (11.1)	2,470 (11.1)	2,695 (12.1)
	5 (127.0)	1,815 (8.2)	2,535 (11.4)	2,120 (9.5)	2,810 (12.6)	2,425 (10.9)	3,080 (13.9)	2,735 (12.3)	3,080 (13.9)
5/8 (15.9)	2 3/4 (69.9)	1,340 (6.0)	1,995 (9.0)	1,635 (7.4)	2,495 (11.2)	1,925 (8.7)	2,995 (13.5)	2,125 (9.6)	2,995 (13.5)
	4 (101.6)	1,615 (7.3)	2,715 (12.2)	2,055 (9.2)	3,180 (14.3)	2,490 (11.2)	3,640 (16.4)	3,275 (14.7)	3,975 (17.9)
	6 (152.4)	2,350 (10.6)	3,445 (15.5)	2,645 (11.9)	4,060 (18.3)	2,935 (13.2)	4,670 (21.0)	3,895 (17.5)	4,670 (21.0)
3/4 (19.1)	3 (76.2)	1,915 (8.6)	3,095 (13.9)	2,145 (9.7)	3,560 (16.0)	2,375 (10.7)	4,025 (18.1)	2,695 (12.1)	4,025 (18.1)
	4 1/2 (114.3)	2,515 (11.3)	4,225 (19.0)	2,800 (12.6)	5,065 (22.8)	3,085 (13.9)	5,900 (26.6)	4,060 (18.3)	5,900 (26.6)
	7 (177.8)	2,945 (13.3)	5,660 (25.5)	3,360 (15.1)	6,470 (29.1)	3,775 (17.0)	7,280 (32.8)	5,495 (24.7)	7,280 (32.8)

1. Allowable load capacities listed are calculated using an applied safety factor of 4.0.
 2. Linear interpolation may be used to determine allowable loads for intermediate embedments and compressive strengths.
 3. Allowable loads for anchors to resist short-term loads such as earthquake or wind may be increased by 33-1/3 percent for the duration of the load, where permitted by code.

PERFORMANCE DATA

Ultimate and Allowable Load Capacities for Carbon and Stainless Steel Power-Bolt in Structural Lightweight Concrete^{1,2,3}

Anchor Diameter <i>d</i> in. (mm)	Minimum Embedment Depth <i>h_v</i> in. (mm)	Minimum Concrete Compressive Strength (<i>f'_c</i>)							
		<i>f'_c</i> = 3,000 psi (20.7 MPa)				<i>f'_c</i> ≥ 5,000 psi (34.5 MPa)			
		Ultimate Load		Allowable Load		Ultimate Load		Allowable Load	
		Tension lbs. (kN)	Shear lbs. (kN)	Tension lbs. (kN)	Shear lbs. (kN)	Tension lbs. (kN)	Shear lbs. (kN)	Tension lbs. (kN)	Shear lbs. (kN)
1/4 (6.4)	1 1/4 (31.8)	1,000 (4.5)	1,520 (6.8)	250 (1.1)	380 (1.7)	1,320 (5.9)	1,520 (6.8)	330 (1.5)	380 (1.7)
	2 (50.8)	1,510 (6.8)	1,540 (6.9)	380 (1.7)	385 (1.7)	–	–	–	–
3/8 (9.5)	2 (50.8)	2,160 (9.7)	2,780 (12.5)	540 (2.4)	695 (3.1)	3,240 (14.6)	2,780 (12.5)	810 (3.6)	695 (3.1)
	3 1/2 (88.9)	4,200 (18.9)	4,980 (22.4)	1,050 (4.7)	1,245 (5.6)	–	–	–	–
1/2 (12.7)	2 1/2 (63.5)	3,680 (16.6)	4,615 (20.8)	920 (4.1)	1,155 (5.2)	4,920 (22.1)	4,615 (20.8)	1,230 (5.5)	1,155 (5.2)
	5 (127.0)	5,540 (24.9)	8,730 (39.3)	1,385 (6.2)	2,185 (9.8)	–	–	–	–
5/8 (15.9)	2 3/4 (69.9)	3,120 (14.0)	6,840 (30.8)	780 (3.5)	1,710 (7.7)	5,240 (23.6)	6,840 (30.8)	1,310 (5.9)	1,710 (7.7)
	6 (152.4)	6,730 (30.3)	14,340 (64.5)	1,685 (7.6)	3,585 (16.1)	–	–	–	–
3/4 (19.1)	3 (76.2)	5,600 (25.2)	8,765 (39.4)	1,400 (6.3)	2,190 (9.9)	7,880 (35.5)	8,765 (39.4)	1,970 (8.9)	2,190 (9.9)
	7 (177.8)	9,860 (44.4)	19,740 (88.8)	2,465 (11.1)	4,935 (22.2)	–	–	–	–

1. The values listed above are ultimate and allowable load capacities for Power-Bolt anchors in sand-lightweight concrete.
 2. Allowable load capacities are calculated using an applied safety factor of 4.0.
 3. Linear interpolation may be used to determine ultimate and allowable loads for intermediate embedments and compressive strengths.

MECHANICAL ANCHORS

PERFORMANCE DATA

Ultimate and Allowable Load Capacities for Carbon and Stainless Steel Power-Bolt Installed Through Metal Deck into Structural Lightweight Concrete^{1,2,3,4}

Anchor Diameter <i>d</i> in. (mm)	Minimum Embedment Depth <i>h_v</i> in. (mm)	Lightweight Concrete over minimum 20 Gage Metal Deck, <i>f'_c</i> ≥ 3,000 (20.7 MPa)							
		Minimum 1-1/2" Wide Deck				Minimum 4-1/2" Wide Deck			
		Ultimate Load		Allowable Load		Ultimate Load		Allowable Load	
		Tension lbs. (kN)	Shear lbs. (kN)	Tension lbs. (kN)	Shear lbs. (kN)	Tension lbs. (kN)	Shear lbs. (kN)	Tension lbs. (kN)	Shear lbs. (kN)
1/4 (6.4)	1 1/4 (31.8)	720 (3.2)	2,360 (10.6)	180 (0.8)	590 (2.7)	920 (4.1)	2,360 (10.6)	230 (1.0)	590 (2.7)
3/8 (9.5)	2 (50.8)	720 (3.2)	2,740 (12.3)	180 (0.8)	685 (3.1)	1,840 (8.3)	2,740 (12.3)	460 (2.1)	685 (3.1)
1/2 (12.7)	2 1/2 (63.5)	1,640 (7.4)	2,740 (12.3)	410 (1.8)	685 (3.1)	2,000 (9.0)	4,400 (19.8)	500 (2.3)	1,100 (5.0)
5/8 (15.9)	2 3/4 (88.9)	-	-	-	-	2,000 (9.0)	4,440 (20.0)	500 (2.3)	1,110 (5.0)
3/4 (19.1)	3 (76.2)	-	-	-	-	4,960 (22.3)	4,480 (20.2)	1,240 (5.6)	1,120 (5.0)

1. The values listed above are ultimate and allowable load capacities for Power-Bolt anchor in sand-lightweight concrete over metal deck.
2. Allowable loads capacities are calculated using an applied safety factor of 4.0.
3. Tabulated load values are for anchors installed in the center of the flute. Spacing distances shall be in accordance with the spacing table for lightweight concrete listed in the Design Criteria section for Power-Bolt.
4. Anchors are permitted to be installed in the lower or upper flute of the metal deck provided the proper installation procedures are maintained.

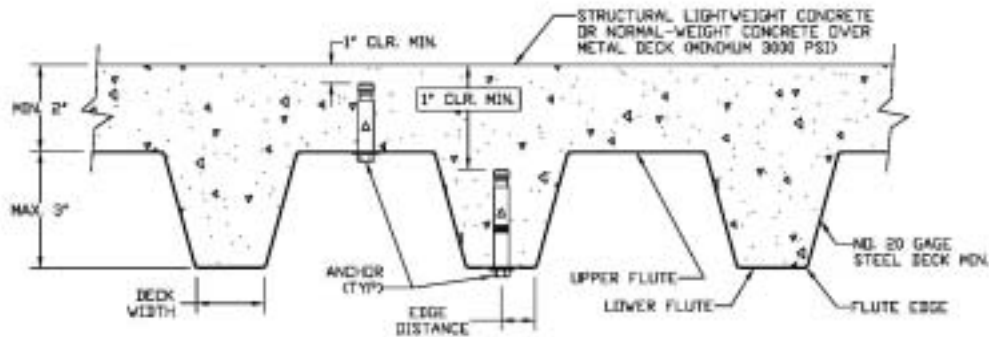

PERFORMANCE DATA

MECHANICAL ANCHORS

Ultimate and Allowable Load Capacities for Power-Bolt in Grout-Filled Concrete Masonry^{1,2,3,4}

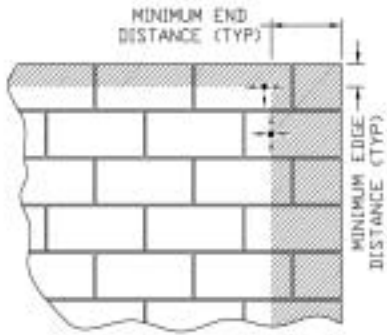

Anchor Diameter <i>d</i> in. (mm)	Minimum Embed. Depth <i>h_v</i> in. (mm)	Minimum Edge Distance in. (mm)	Minimum End Distance in. (mm)	<i>f'_m</i> ≥ 1,500 psi (10.4 MPa)			
				Ultimate Load		Allowable Load	
				Tension lbs. (kN)	Shear lbs. (kN)	Tension lbs. (kN)	Shear lbs. (kN)
1/4 (6.4)	1 1/8 (28.6)	3 3/4 (95.3)	3 3/4 (95.3)	1,215 (5.5)	1,185 (5.3)	245 (1.1)	235 (1.1)
	2 1/2 (63.5)	5 1/4 (133.4)	3 3/4 (95.3)	1,760 (7.9)	1,185 (5.3)	350 (1.6)	235 (1.1)
3/8 (9.5)	2 (50.8)	5 5/8 (142.9)	5 5/8 (142.9)	1,985 (8.9)	3,065 (13.8)	395 (1.8)	615 (2.8)
	3 1/2 (88.9)	7 7/8 (200.0)	5 5/8 (142.9)	2,120 (9.5)	3,065 (13.8)	425 (1.9)	615 (2.8)
1/2 (12.7)	2 1/2 (63.5)	7 1/2 (190.5)	7 1/2 (190.5)	2,435 (11.0)	5,650 (25.4)	485 (2.2)	1,130 (5.1)
	4 (101.6)	10 1/2 (266.7)	7 1/2 (190.5)	2,690 (12.1)	5,650 (25.4)	540 (2.4)	1,130 (5.1)
5/8 (15.9)	2 3/4 (69.9)	9 3/8 (238.1)	9 3/8 (238.1)	2,560 (11.5)	9,000 (40.5)	510 (2.3)	1,800 (8.1)
	5 (127.0)	13 1/8 (333.4)	9 3/8 (238.1)	2,975 (13.4)	9,000 (40.5)	595 (2.7)	1,800 (8.1)
3/4 (19.1)	3 (76.2)	11 1/4 (285.8)	11 1/4 (285.8)	3,345 (15.0)	9,870 (44.4)	670 (3.0)	1,975 (8.9)
	5 (127.0)	15 3/4 (400.1)	11 1/4 (285.8)	4,250 (19.1)	9,870 (44.4)	850 (3.8)	1,975 (8.9)

1. Tabulated load values are for carbon and stainless steel anchors installed in minimum 6-inch wide, Grade N, Type II, medium and normal weight concrete masonry units. Mortar must be minimum Type N. Masonry prism compressive strength must be 1,500 psi minimum at the time of installation.
2. Allowable loads are for carbon and stainless steel anchors and are based on average ultimate values using a safety factor of 5.0.
3. Linear interpolation may be used to determine ultimate and allowable loads for intermediate embedment depths.
4. The tabulated values are for anchors installed at a minimum of 12 anchor diameters on center for 100 percent capacity. Spacing distances may be reduced to 6 anchor diameters on center provided the capacities are reduced by 50 percent. Linear interpolation may be used for intermediate spacing.

Ultimate and Allowable Load Capacities for Power-Bolt in Hollow Concrete Masonry^{1,2,3,4,5}

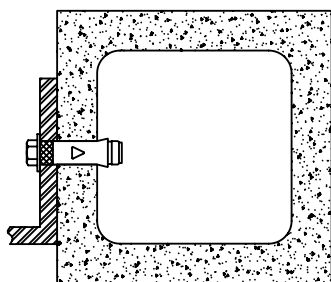

Anchor Diameter <i>d</i> in. (mm)	Minimum Embed. Depth <i>h_v</i> in. (mm)	Minimum Edge Distance in. (mm)	Minimum End Distance in. (mm)	<i>f'_m</i> ≥ 1,500 psi (10.4 MPa)			
				Ultimate Load		Allowable Load	
				Tension lbs. (kN)	Shear lbs. (kN)	Tension lbs. (kN)	Shear lbs. (kN)
1/4 (6.4)	7/8 (22.2)	3 3/4 (95.3)	3 3/4 (95.3)	600 (2.7)	765 (3.4)	120 (0.5)	155 (0.7)
	1 1/4 (31.8)	3 3/4 (95.3)	8 (203.2)	825 (3.7)	1,055 (4.8)	165 (0.7)	210 (0.9)
	1 1/2 (38.1)	3 3/4 (95.3)	12 (304.8)	1,130 (5.1)	1,230 (5.5)	225 (1.0)	245 (1.1)
3/8 (9.5)	1 1/4 (31.8)	12 (304.8)	8 (203.2)	1,360 (6.1)	2,150 (9.7)	270 (1.2)	430 (1.9)
	1 1/2 (38.1)	12 (304.8)	12 (304.8)	1,470 (6.6)	2,600 (11.7)	295 (1.3)	520 (2.3)
1/2 (12.7)	1 1/4 (31.8)	12 (304.8)	8 (203.2)	2,560 (11.5)	2,150 (9.7)	590 (2.4)	430 (1.9)
	1 1/2 (38.1)	12 (304.8)	12 (304.8)	2,560 (11.5)	3,385 (15.2)	510 (2.3)	675 (3.0)

1. Tabulated load values are for carbon and stainless steel anchors installed in minimum 6-inch wide, Grade N, Type II, medium and normal weight concrete masonry units. Mortar must be minimum Type N. Masonry prism compressive strength must be 1,500 psi minimum at the time of installation.
2. Allowable loads are for carbon and stainless steel anchors and are based on average ultimate values using a safety factor of 5.0.
3. Linear interpolation may be used to determine ultimate and allowable loads for intermediate embedment depths.
4. The tabulated values are for anchors installed at a minimum of 12 anchor diameters on center for 100 percent capacity. Spacing distances may be reduced to 6 anchor diameters on center provided the capacities are reduced by 50 percent. Linear interpolation may be used for intermediate spacing.
5. Anchors with diameters of 1/2" and larger installed in hollow concrete masonry units are limited to one anchor per unit cell.

PERFORMANCE DATA

Ultimate and Allowable Load Capacities for Power-Bolt in Clay Brick Masonry^{1,2,3}

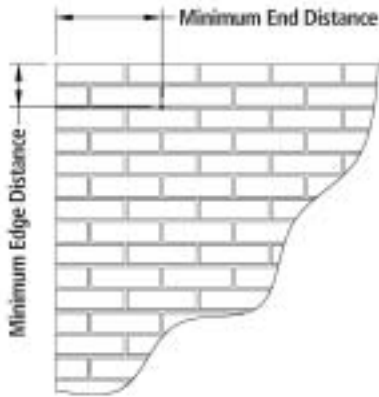

Anchor Dia. <i>d</i> in. (mm)	Min. Embed. Depth <i>h_v</i> in. (mm)	Min. Edge Distance	Min. End Distance	Spacing Distance	Structural Brick Masonry <i>f'_m</i> ≥ 1,500 psi (10.4 MPa)			
					Ultimate Load		Allowable Load	
					Tension lbs. (kN)	Shear lbs. (kN)	Tension lbs. (kN)	Shear lbs. (kN)
1/4 (6.4)	7/8 (22.2)	8 (203.2)	4 (101.6)	6 (152.4)	1,090 (4.9)	1,160 (5.2)	220 (1.0)	230 (1.0)
	1 1/2 (38.1)				1,455 (6.6)	1,265 (5.7)	290 (1.3)	255 (1.1)
3/8 (9.5)	2 (50.8)	12 (304.8)	6 (152.4)	8 (203.2)	2,015 (9.1)	3,655 (16.5)	405 (1.8)	730 (3.3)
1/2 (12.7)	2 1/2 (63.5)		8 (203.2)	10 (254.0)	3,110 (14.0)	4,585 (20.6)	620 (2.8)	915 (4.1)
5/8 (15.9)	2 3/4 (69.9)	16 (406.4)	10 (254.0)	12 (304.8)	4,535 (20.4)	5,470 (24.6)	905 (4.1)	1,095 (4.9)
3/4 (19.1)	3 (76.2)		12 (304.8)	16 (406.4)	5,930 (26.7)	6,770 (30.5)	1,185 (5.3)	1,355 (6.1)

1. Tabulated load values are for carbon and stainless steel anchors installed in Grade SW multiple wythe, solid brick masonry conforming to ASTM C62.
2. Allowable loads are calculated using an applied safety factor of 5.0.
3. Spacing between anchors may be reduced to half the listed distances provided the capacities are reduced by 50 percent. Linear interpolation may be used for intermediate spacing.

DESIGN CRITERIA

Combined Loading

For anchors loaded in both shear and tension, the combination of loads should be proportioned as follows:

$$\left(\frac{N_u}{N_n}\right)^{\frac{5}{3}} + \left(\frac{V_u}{V_n}\right)^{\frac{5}{3}} \leq 1 \quad \text{OR} \quad \left(\frac{N_u}{N_n}\right) + \left(\frac{V_u}{V_n}\right) \leq 1$$

Where: *N_u* = Applied Service Tension Load
N_n = Allowable Tension Load
V_u = Applied Service Shear Load
V_n = Allowable Shear Load

Load Adjustment Factors for Spacing and Edge Distances

Anchor Installed in Normal-Weight Concrete					
Anchor Dimension	Load Type	Critical Distance (Full Anchor Capacity)	Critical Load Factor	Minimum Distance (Reduced Capacity)	Minimum Load Factor
Spacing (<i>s</i>)	Tension and Shear	<i>s_{cr}</i> = 2.0 <i>h_v</i>	<i>F_N</i> = <i>F_V</i> = 1.0	<i>s_{min}</i> = <i>h_v</i>	<i>F_N</i> = <i>F_V</i> = 0.50
Edge Distance (<i>c</i>)	Tension	<i>c_{cr}</i> = 12 <i>d</i>	<i>F_N</i> = 1.0	<i>c_{min}</i> = 5 <i>d</i>	<i>F_N</i> = 0.70
	Shear	<i>c_{cr}</i> = 12 <i>d</i>	<i>F_V</i> = 1.0	<i>c_{min}</i> = 5 <i>d</i>	<i>F_V</i> = 0.35

Anchor Installed in Lightweight Concrete					
Anchor Dimension	Load Type	Critical Distance (Full Anchor Capacity)	Critical Load Factor	Minimum Distance (Reduced Capacity)	Minimum Load Factor
Spacing (<i>s</i>)	Tension and Shear	<i>s_{cr}</i> = 2.0 <i>h_v</i>	<i>F_N</i> = <i>F_V</i> = 1.0	<i>s_{min}</i> = <i>h_v</i>	<i>F_N</i> = <i>F_V</i> = 0.50
Edge Distance (<i>c</i>)	Tension	<i>c_{cr}</i> = 12 <i>d</i>	<i>F_N</i> = 1.0	<i>c_{min}</i> = 5 <i>d</i>	<i>F_N</i> = 0.80
	Shear	<i>c_{cr}</i> = 12 <i>d</i>	<i>F_V</i> = 1.0	<i>c_{min}</i> = 5 <i>d</i>	<i>F_V</i> = 0.40

DESIGN CRITERIA

Load Adjustment Factors for Normal-Weight Concrete

Spacing, Tension (F_N) & Shear (F_V)															
Dia. (in.)	1/4			3/8			1/2			5/8			3/4		
h_v (in.)	1 1/4	1 3/4	2 1/2	2	2 1/2	3 1/2	2 1/2	3 1/2	5	2 3/4	4	6	3	4 1/2	7
s_{cr} (in.)	2 1/2	3 1/2	5	4	5	7	5	7	10	5 1/2	8	12	6	9	14
s_{min} (in.)	1 1/4	1 3/4	2 1/2	2	2 1/2	3 1/2	2 1/2	3 1/2	5	2 3/4	4	6	3	4 1/2	7
Spacing, s (inches)	1 1/4	0.50													
	1 3/4	0.70	0.50												
	2	0.80	0.57	0.50											
	2 1/2	1.00	0.71	0.50	0.63	0.50		0.50							
	2 3/4		0.79	0.55	0.69	0.55		0.55		0.50					
	3		0.86	0.60	0.75	0.60		0.60		0.55			0.50		
	3 1/2		1.00	0.70	0.88	0.70	0.50	0.70	0.50	0.64			0.58		
	4			0.80	1.00	0.80	0.57	0.80	0.57	0.73	0.50		0.67		
	4 1/2			0.90		0.90	0.64	0.90	0.64	0.82	0.56		0.75	0.50	
	5			1.00		1.00	0.71	1.00	0.71	0.91	0.63		0.83	0.56	
	5 1/2						0.79		0.79	0.55	1.00	0.69	0.92	0.61	
	6						0.86		0.86	0.60		0.75	0.50	1.00	0.67
	7						1.00		1.00	0.70		0.88	0.58	0.78	0.50
	8									0.80	1.00	0.67		0.89	0.57
	9									0.90		0.75		1.00	0.64
10									1.00		0.83			0.71	
12											1.00			0.86	
14														1.00	

Notes: For anchors loaded in tension and shear, the critical spacing (s_{cr}) is equal to 2 embedment depths ($2h_v$) at which the anchor achieves 100% of load.

Minimum spacing (s_{min}) is equal to 1 embedment depth (h_v) at which the anchor achieves 50% of load.

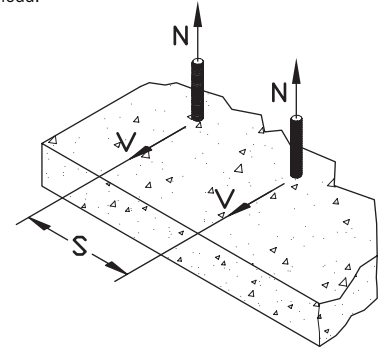

Edge Distance, Tension (F_N)						
Dia. (in.)	1/4	3/8	1/2	5/8	3/4	
c_{cr} (in.)	3	4 1/2	6	7 1/2	9	
c_{min} (in.)	1 1/4	1 7/8	2 1/2	3 1/8	3 3/4	
Edge Distance, c (inches)	1 1/4	0.70				
	1 5/8	0.76				
	1 7/8	0.81	0.70			
	2	0.83	0.71			
	2 1/2	0.91	0.77	0.70		
	3	1.00	0.83	0.74		
	3 1/8		0.84	0.75	0.70	
	3 3/4		0.91	0.81	0.74	0.70
	4		0.94	0.83	0.76	0.71
	4 1/2		1.00	0.87	0.79	0.74
	5			0.91	0.83	0.77
	6			1.00	0.90	0.83
	6 1/4				0.91	0.84
	7				0.97	0.89
	7 1/2				1.00	0.91
8					0.94	
9					1.00	

Notes: For anchors loaded in tension, the critical edge distance (c_{cr}) is equal to 12 anchor diameters ($12d$) at which the anchor achieves 100% of load.

Minimum edge distance (c_{min}) is equal to 5 anchor diameters ($5d$) at which the anchor achieves 70% of load.

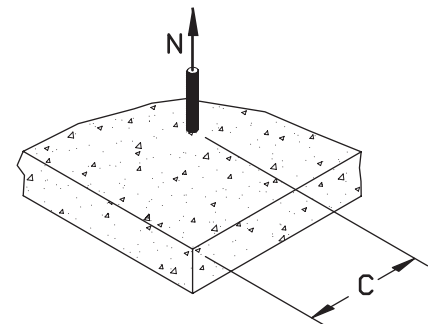

Edge Distance, Shear (F_V)						
Dia. (in.)	1/4	3/8	1/2	5/8	3/4	
c_{cr} (in.)	3	4 1/2	6	7 1/2	9	
c_{min} (in.)	1 1/4	1 7/8	2 1/2	3 1/8	3 3/4	
Edge Distance, c (inches)	1 1/4	0.35				
	1 5/8	0.49				
	1 7/8	0.58	0.35			
	2	0.63	0.38			
	2 1/2	0.81	0.50	0.35		
	3	1.00	0.63	0.44		
	3 1/8		0.66	0.47	0.35	
	3 3/4		0.81	0.58	0.44	0.35
	4		0.88	0.63	0.48	0.38
	4 1/2		1.00	0.72	0.55	0.44
	5			0.81	0.63	0.50
	6			1.00	0.78	0.63
	6 1/4				0.81	0.66
	7				0.93	0.75
	7 1/2				1.00	0.81
8					0.88	
9					1.00	

Notes: For anchors loaded in shear, the critical edge distance (c_{cr}) is equal to 12 anchor diameters ($12d$) at which the anchor achieves 100% of load.

Minimum edge distance (c_{min}) is equal to 5 anchor diameters ($5d$) at which the anchor achieves 35% of load.

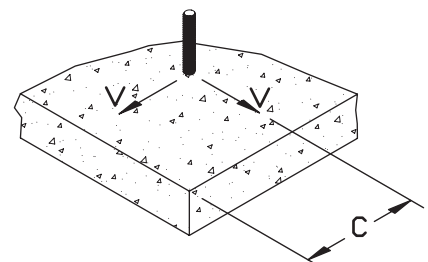

DESIGN CRITERIA

Load Adjustment Factors for Lightweight Concrete

Spacing, Tension (F_N) & Shear (F_V)															
Dia. (in.)	1/4			3/8			1/2			5/8			3/4		
h_v (in.)	1 1/4	1 3/4	2 1/2	2	2 1/2	3 1/2	2 1/2	3 1/2	5	2 3/4	4	6	3	4 1/2	7
S_{cr} (in.)	2 1/2	3 1/2	5	4	5	7	5	7	10	5 1/2	8	12	6	9	14
S_{min} (in.)	1 1/4	1 3/4	2 1/2	2	2 1/2	3 1/2	2 1/2	3 1/2	5	2 3/4	4	6	3	4 1/2	7
Spacing, s (inches)	1 1/4	0.50													
	1 3/4	0.70	0.50												
	2	0.80	0.57		0.50										
	2 1/2	1.00	0.71	0.50	0.63	0.50		0.50							
	2 3/4		0.79	0.55	0.69	0.55		0.55			0.50				
	3		0.86	0.60	0.75	0.60		0.60			0.55			0.50	
	3 1/2		1.00	0.70	0.88	0.70	0.50	0.70	0.50		0.64			0.58	
	4			0.80	1.00	0.80	0.57	0.80	0.57		0.73	0.50		0.67	
	4 1/2				0.90	0.64	0.90	0.64			0.82	0.56		0.75	0.50
	5			1.00		1.00	0.71	1.00	0.71	0.50	0.91	0.63		0.83	0.56
	5 1/2					0.79		0.79	0.55	1.00	0.69			0.92	0.61
	6					0.86		0.86	0.60		0.75	0.50	1.00	0.67	
	7					1.00		1.00	0.70		0.88	0.58		0.78	0.50
	8								0.80		1.00	0.67		0.89	0.57
9								0.90			0.75	1.00	0.64		
10								1.00			0.83		0.71		
12											1.00		0.86		
14													1.00		

Notes: For anchors loaded in tension and shear, the critical spacing (S_{cr}) is equal to 2 embedment depths ($2 h_v$) at which the anchor achieves 100% of load.

Minimum spacing (S_{min}) is equal to 1 embedment depth (h_v) at which the anchor achieves 50% of load.

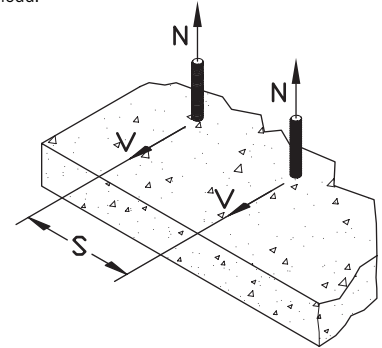

Edge Distance, Tension (F_N)					
Dia. (in.)	1/4	3/8	1/2	5/8	3/4
C_{cr} (in.)	3	4 1/2	6	7 1/2	9
C_{min} (in.)	1 1/4	1 7/8	2 1/2	3 1/8	3 3/4
Edge Distance, c (inches)	1 1/4	0.80			
	1 5/8	0.84			
	1 7/8	0.87	0.80		
	2	0.89	0.81		
	2 1/2	0.94	0.85	0.80	
	3	1.00	0.89	0.83	
	3 1/8		0.90	0.84	0.80
	3 3/4		0.94	0.87	0.83
	4		0.96	0.89	0.84
	4 1/2		1.00	0.91	0.86
	5			0.94	0.89
	6			1.00	0.93
	6 1/4				0.94
	7				0.98
7 1/2				1.00	
8				0.96	
9				1.00	

Notes: For anchors loaded in tension, the critical edge distance (C_{cr}) is equal to 12 anchor diameters ($12d$) at which the anchor achieves 100% of load.

Minimum edge distance (C_{min}) is equal to 5 anchor diameters ($5d$) at which the anchor achieves 80% of load.

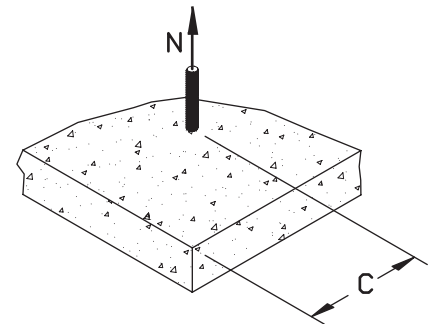

Edge Distance, Shear (F_V)					
Dia. (in.)	1/4	3/8	1/2	5/8	3/4
C_{cr} (in.)	3	4 1/2	6	7 1/2	9
C_{min} (in.)	1 1/4	1 7/8	2 1/2	3 1/8	3 3/4
Edge Distance, c (inches)	1 1/4	0.40			
	1 5/8	0.53			
	1 7/8	0.61	0.40		
	2	0.66	0.43		
	2 1/2	0.83	0.54	0.40	
	3	1.00	0.66	0.49	
	3 1/8		0.69	0.51	0.40
	3 3/4		0.83	0.61	0.49
	4		0.89	0.66	0.52
	4 1/2		1.00	0.74	0.59
	5			0.83	0.66
	6			1.00	0.79
	6 1/4				0.83
	7				0.93
7 1/2				1.00	
8				0.89	
9				1.00	

Notes: For anchors loaded in shear, the critical edge distance (C_{cr}) is equal to 12 anchor diameters ($12d$) at which the anchor achieves 100% of load.

Minimum edge distance (C_{min}) is equal to 5 anchor diameters ($5d$) at which the anchor achieves 40% of load.

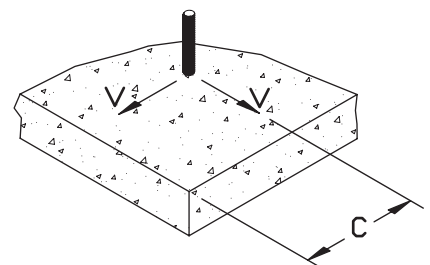

ORDERING INFORMATION

Carbon Steel Hex Head Power-Bolt

Cat. No.	Anchor Size	Drill Dia.	Min. Embed.	Std. Box	Std. Carton	Wt./100
6900	1/4" x 1"	1/4"	7/8"	100	600	2
6902	1/4" x 1 3/4"	1/4"	1-1/4"	100	600	3
6906	1/4" x 3"	1/4"	1-1/4"	100	600	5
6907	5/16" x 1 3/4"	5/16"	1-1/2"	100	600	5
6908	5/16" x 2 1/2"	5/16"	1-1/2"	50	300	6
6909	5/16" x 3 1/2"	5/16"	1-1/2"	50	300	8
6910	3/8" x 2 1/4"	3/8"	2"	50	300	8
6911*	3/8" x 1 7/8"	3/8"	1-1/4"	100	600	6
6913	3/8" x 3"	3/8"	2"	50	300	11
6914	3/8" x 3 1/2"	3/8"	2"	50	300	12
6916	3/8" x 4"	3/8"	2"	50	300	14
6930	1/2" x 2 3/4"	1/2"	2-1/2"	50	200	16
6932	1/2" x 3 3/4"	1/2"	2-1/2"	25	150	21
6934	1/2" x 4 3/4"	1/2"	2-1/2"	25	150	26
6936	1/2" x 5 3/4"	1/2"	2-1/2"	25	150	32
6940	5/8" x 3"	5/8"	2-3/4"	20	120	28
6942	5/8" x 4"	5/8"	2-3/4"	15	90	40
6944	5/8" x 5"	5/8"	2-3/4"	15	90	47
6945	5/8" x 6"	5/8"	2-3/4"	15	90	57
6947	5/8" x 8 1/2"	5/8"	2-3/4"	10	40	77
6950	3/4" x 3 1/4"	3/4"	3"	15	90	47
6952	3/4" x 4 1/4"	3/4"	3"	10	60	58
6954	3/4" x 5 1/4"	3/4"	3"	10	60	70
6956	3/4" x 7 1/4"	3/4"	3"	10	40	105
6957	3/4" x 8 1/4"	3/4"	3"	10	40	110



MECHANICAL ANCHORS

The published length is measured from below the washer to the end of the anchor.
*This size does not have a compression ring.

Carbon Steel Flat Head Power-Bolt

Cat. No.	Anchor Size	Drill Dia.	Min. Embed.	Std. Box	Std. Carton	Wt./100
6981	3/8" x 3 3/4"	3/8"	2"	50	300	14
6982	3/8" x 5"	3/8"	2"	50	300	17
6983	3/8" x 6"	3/8"	2"	50	300	20
6984	1/2" x 5"	1/2"	2-1/2"	25	150	26
6987	5/8" x 5 1/2"	5/8"	2-3/4"	15	90	57

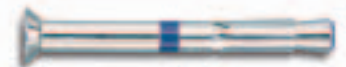

The published length is the overall length of the anchor.
The flat head Power-Bolt anchor has a hex key insert formed in the head of the bolt.
Each box contains an Allen wrench which matches the insert size.

Stainless Steel Hex Head Power-Bolt

Cat. No.	Anchor Size	Drill Dia.	Min. Embed.	Std. Box	Std. Carton	Wt./100
5900*	1/4" x 1"	1/4"	7/8"	100	600	2
5902	1/4" x 1 3/4"	1/4"	1-1/4"	100	600	3
5906	1/4" x 3"	1/4"	1-1/4"	100	600	5
5910	3/8" x 2 1/4"	3/8"	2"	50	300	10
5914	3/8" x 3 1/2"	3/8"	2"	50	300	12
5916	3/8" x 4"	3/8"	2"	50	300	14
5930	1/2" x 2 3/4"	1/2"	2-1/2"	50	200	16
5934	1/2" x 4 3/4"	1/2"	2-1/2"	25	150	26
5944	5/8" x 5"	5/8"	2-3/4"	15	90	47
5946	5/8" x 7"	5/8"	2-3/4"	15	60	67
5954	3/4" x 5-1/4"	3/4"	3"	15	60	70
5957	3/4" x 8 1/4"	3/4"	3"	10	40	110



The published length is measured from below the washer to the end of the anchor.
*This size does not have a compression ring.